

ELECTRIC MUFFLE KILN WITH REMOTE CONTROLLED DOOR - USER MANUAL

PRODUCT INTRODUCTION:

THIS SK-1200P SMART KILN IS A MULTI-FUNCTIONAL ELECTRIC MUFFLE KILN WITH REMOTE CONTROL (KILN ON/OFF AND OPEN/CLOSE DOOR FUNCTIONS). THIS KILN HAS A 32-SEGMENT PROGRAMMABLE TEMPERATURE CONTROLLER. ITS 16.0 CUBIC LITRE CHAMBER HAS FOUR HEATING ELEMENTS AT THE TOP AND THE KILN IS SPECIFICALLY DESIGNED TO WORK WITH ALL TYPES OF MATERIALS, INCLUDING GLASS, WAXES, WOOD, METALS, CLAY, STONE, HOT ENAMEL, GLAZES AND ANY OTHER MATERIALS WITH FIRING TEMPERATURES OF UNDER 1,200°C/2,192°F. THIS KILN HAS AN EMERGENCY SWITCH FOR YOUR SAFETY. FOR VENTILATION IT HAS TWO HOLES ON THE DOOR WITH STAINLESS-STEEL SHUTTERS AND CAN BE UPGRADED IN THE FUTURE WITH A FULLY AUTOMATIC, FORCED, LASER-BASED, AIR EXTRACTION SYSTEM. IT ALSO HAS A DIGITAL OVER/UNDER TEMPERATURE DETECTION SYSTEM TO HELP MAINTAIN A CONSTANT TEMPERATURE DURING THE ENTIRE SOAKING PROCESS. THIS KILN ALSO HAS A SMOOTHING CIRCUIT TO ALLOW THE PROGRAMMABLE CONTROLLER TO CORRECTLY READ AND STABILISE ELECTRICITY FLUCTUATIONS, WHICH IS ESSENTIAL FOR MOST FIRING PROCESSES.

Pic. 1

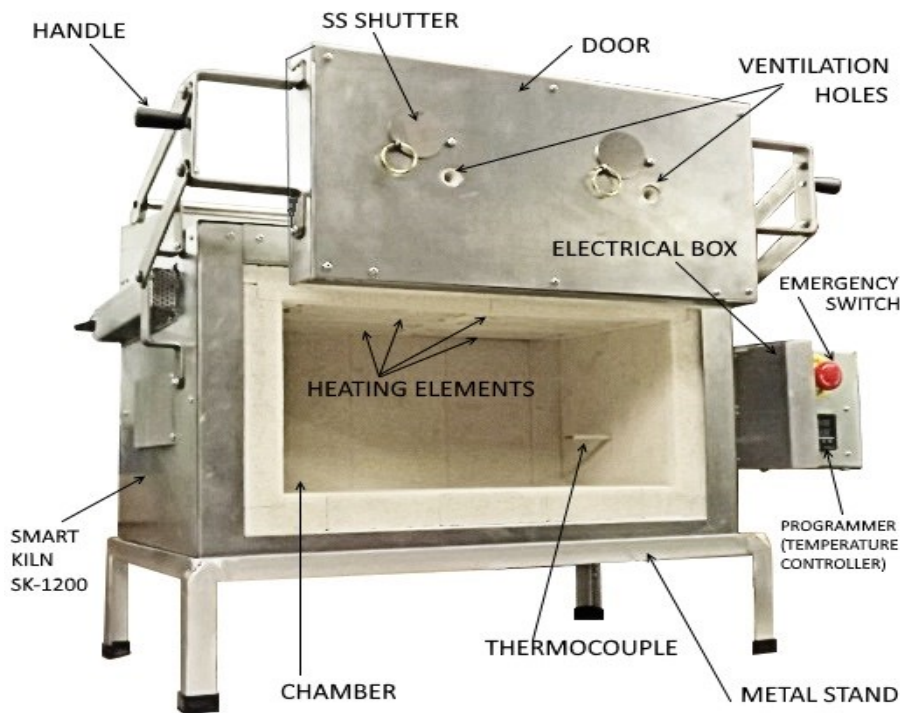

MODEL:	SK-1200P	CALIBRATION:	YES
INPUT ON REQUEST:	115, 220 or 240 V	SOAKING PROCESS ACCURACY:	+/- 1°C
POWER:	3,600 WATT	EMERGENCY SAFETY SWITCH:	Yes
ESTIMATED MAXIMUM HEATING TEMPERATURE:	1,200°C/2,192°F	AUTOMATIC OPTIONS:	POWER ON/OFF DOOR OPEN/CLOSE
ESTIMATED HEATING TIME TO 1,200°C:	90 MINUTES	HEATING ELEMENTS:	FOUR (AT THE TOP)
CONTROLLER TYPE:	STANDARD, TWO-LINE	CHAMBER'S INTERNAL DIMENSIONS MM (INCH):	400(w) X 200(h) X 200(l) 16" x 8" x 8"
CONTINUOUS WORKING TIME AT 1,200°C:	30 MINUTES	KILN DIMENSIONS MM (INCH) (INCL. METAL STAND, EXCL. MAIN DOOR'S ARM)	700(w) x 530(h) x 400(l) 28" x 21" x 16"
CONTINUOUS WORKING TIME BELOW 1,000°C:	8 HOURS	WEIGHT:	49 KG

Pic. 2

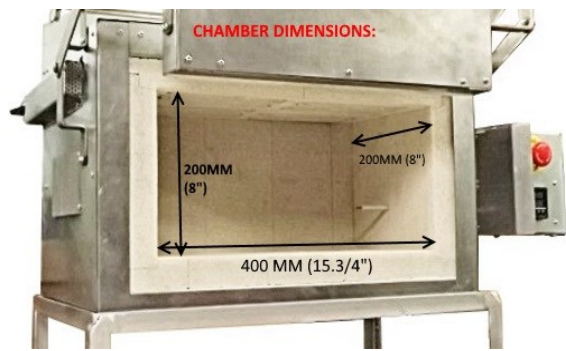

Pic. 4

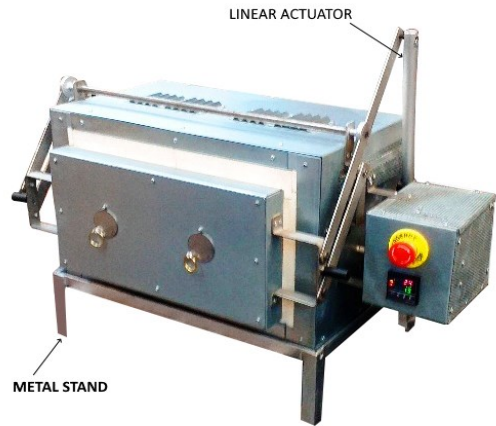

Pic. 3

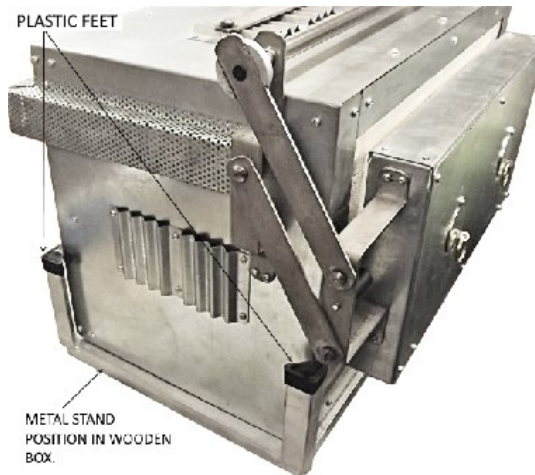

Pic. 5

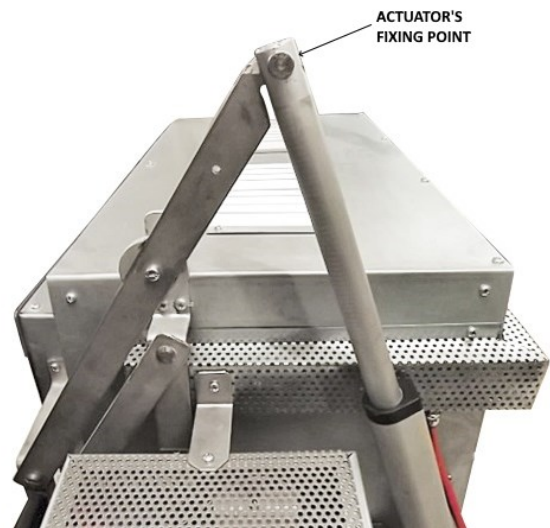

PREPARATION:

- ◆ Open the wooden box or pallet wrap.
- ◆ Lift and move the kiln onto a worktop that is able to hold about 80 kg of weight. Because this kiln weighs about 50 kg (with the stand) please ask for help. Do not move it alone; mechanical damages are **NOT UNDER WARRANTY**. Please note that this kiln was packed together with its metal stand. This metal stand is usually in the position pictured in Pic. 3 when you unpack the kiln. Its normal working position is shown in Pic. 1. If you have any questions about unpacking and installing this kiln please feel free to contact us by email or email us to book a Skype or WhatsApp appointment with an engineer who can help you with the assembly.
- ⇒ **STEP ONE:** TWO people should move this kiln from the box/pallet and hold it while ONE MORE person moves the metal stand and puts it on the worktop in the working position shown in Pics. 1 and 4. Depending on the model, plastic feet may already be attached to the stand. If not then you will find these inside the chamber and be able to attach them later .
- ⇒ **STEP TWO:** Please place this kiln towards the LEFT side of the stand because of the actuator with motor attached to the right of the kiln. Please see Pic. 4 and Pic. 5 for more information about this actuator's correct position and fixing.

ATTACHING THE ACTUATOR:

- ⇒ Before you attach the linear actuator, open the door of your kiln using the left and right handles and carefully take out all the packing materials and accessories from the chamber, including the electrical box with programmable temperature controller, the actuator, K-thermocouple and remote controller.
- ⇒ If not already attached, fix the actuator to the metal stand and to the top metal arm using M6 screws (supplied) as shown in Pics. 6 and 7 below:

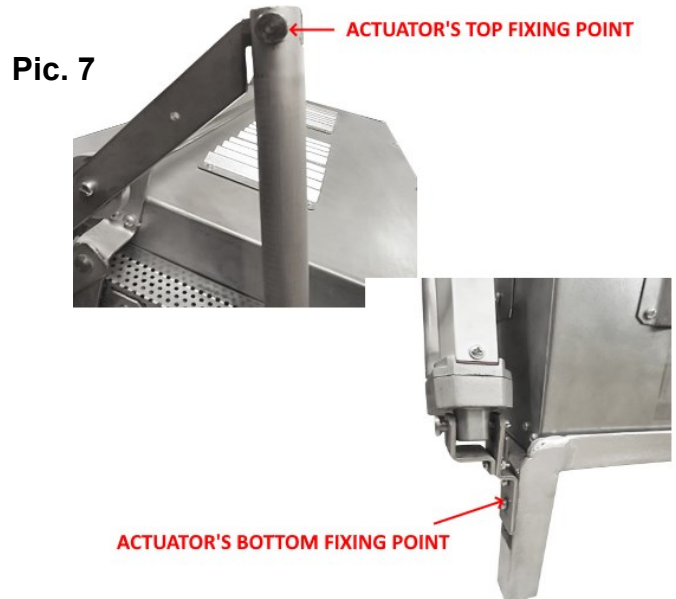
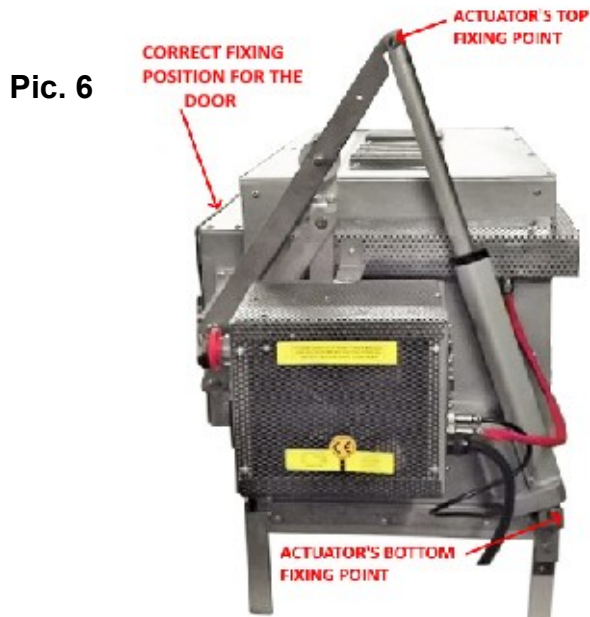

- ⇒ To open the door of your kiln manually (for example in emergencies or when the power supply is disconnected) your kiln's door has two black handles that have been attached INSIDE the shackles on the left and right side of the door for delivery purposes (Pic. 8). Please unscrew them and then screw them on as shown in Pic. 9. Please remember that you should only open the door manually in an emergency because the door can't be fixed open in this way.

Pic. 8

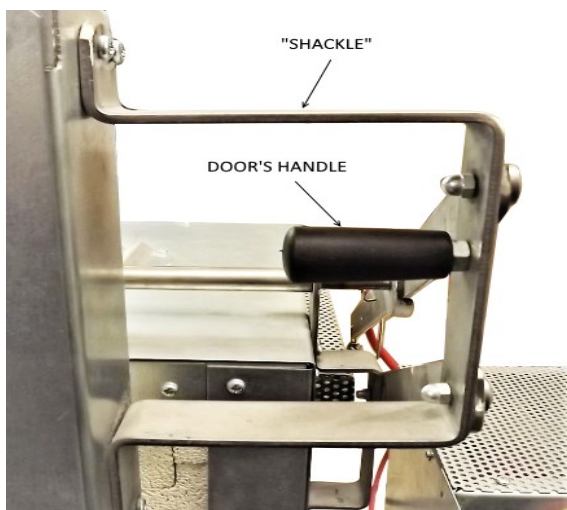

Pic. 9

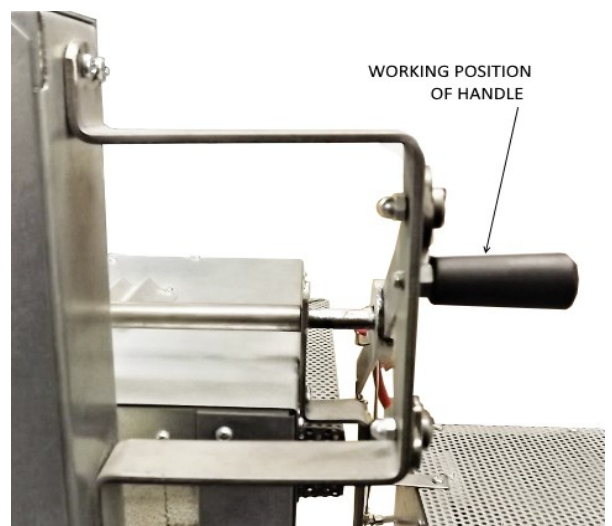

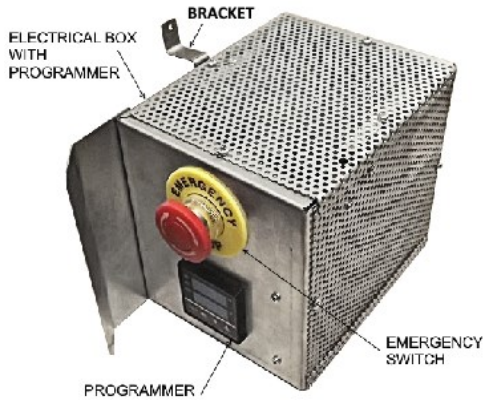
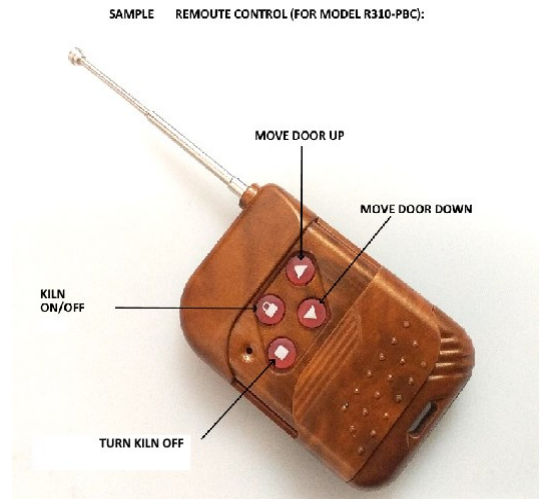
ELECTRICAL BOX:**K-thermocouple:**

⇒ If it is not yet installed, attach the K-thermocouple to the programmable temperature controller inside the electrical box. To do this take the electrical box with stainless steel brackets (top left image above) and insert thermocouple (top middle image above) into the hole at the bottom as shown in Pic. 9 and 10 below.

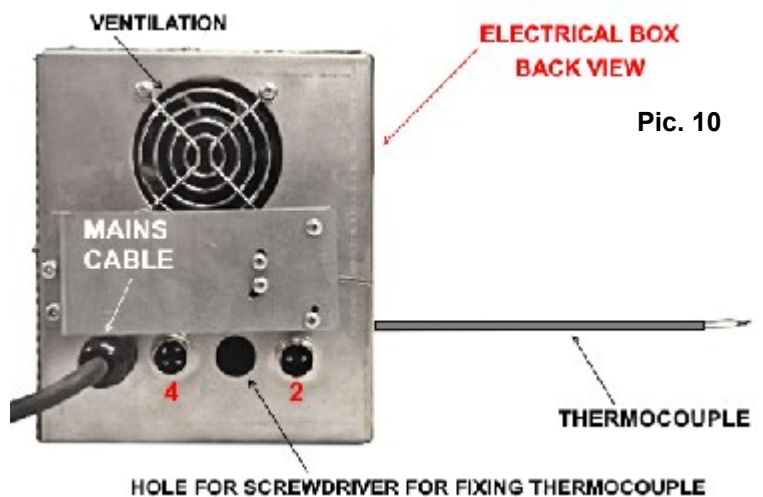
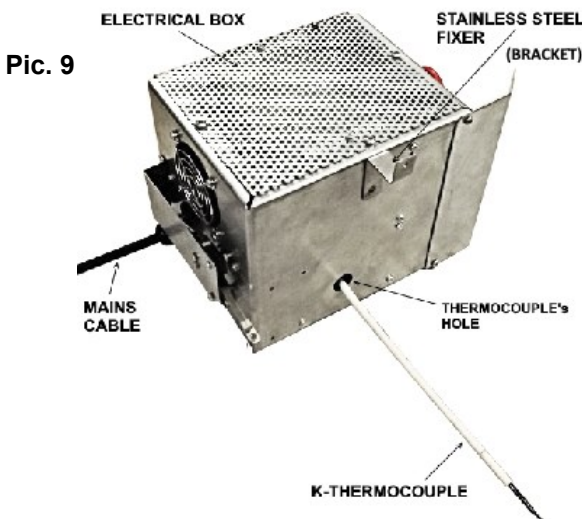

Please note that your thermocouple has SHORT and LONG wires at one end (Pic. 11). The thermocouple's LONG wire should be inserted and fixed into the bottom right connection terminal and the SHORT wire should be fixed to the terminal above it, as shown in Pics. 11 and 12. You can see the two terminals and use a screwdriver through the hole shown in Pic. 10.

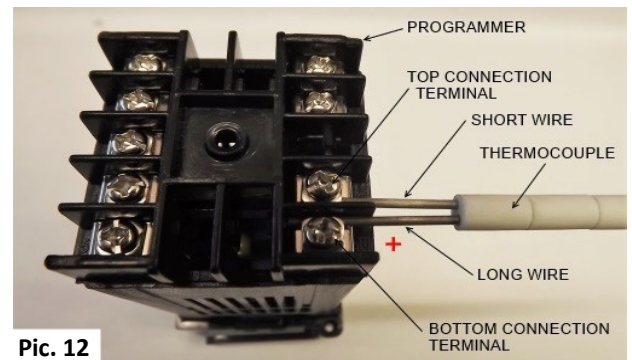
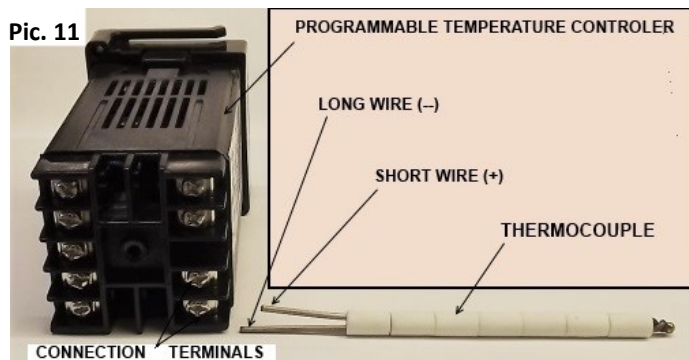

- Please ensure that the thermocouple is attached properly and correctly with the LONG wire on the bottom connection terminal, as shown in Pic. 12. This is a critical part of the programmable temperature controller; if attached incorrectly the controller will count the temperature down (incorrectly) or just display "0000" or "UUUU" on the top line, depending on the type of controller.

- ⇒ After you have attached the thermocouple to the programmable temperature controller you can attach the electrical box (Pic. 15) to the right side of the kiln. To do this insert the visible end of the thermocouple into the hole in the left wall of the kiln's body and attach the electrical box by screwing in three stainless steel pins (fixers) as shown in Pics. 13 and 14.

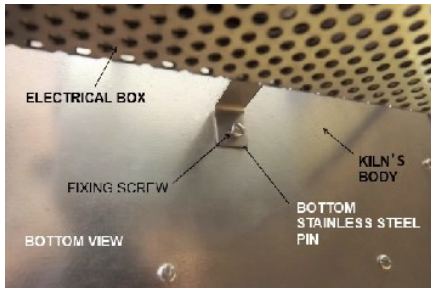
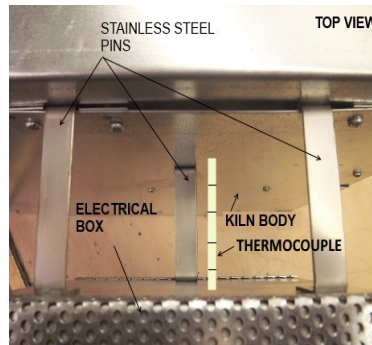
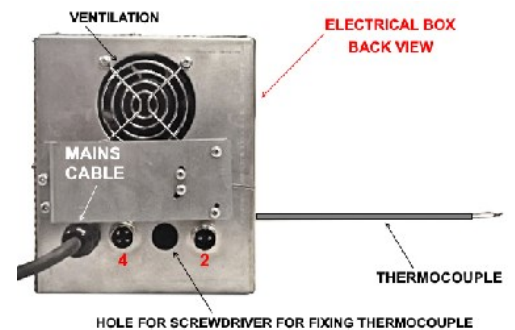
Pic. 13**Pic. 14****Pic. 15**

- ⇒ When the electrical box is attached, connect both RED cables from the actuator's motor and the heating elements to terminals no. 4 (4-pin) and no. 2 (2-pin) on the back side of the electrical box. You can see both terminals labelled in RED in Pic. 15: number 4 (4-pin terminal) and number 2 (2-pin terminal). When inserted correctly, tighten the round nuts of both terminals securely by hand.

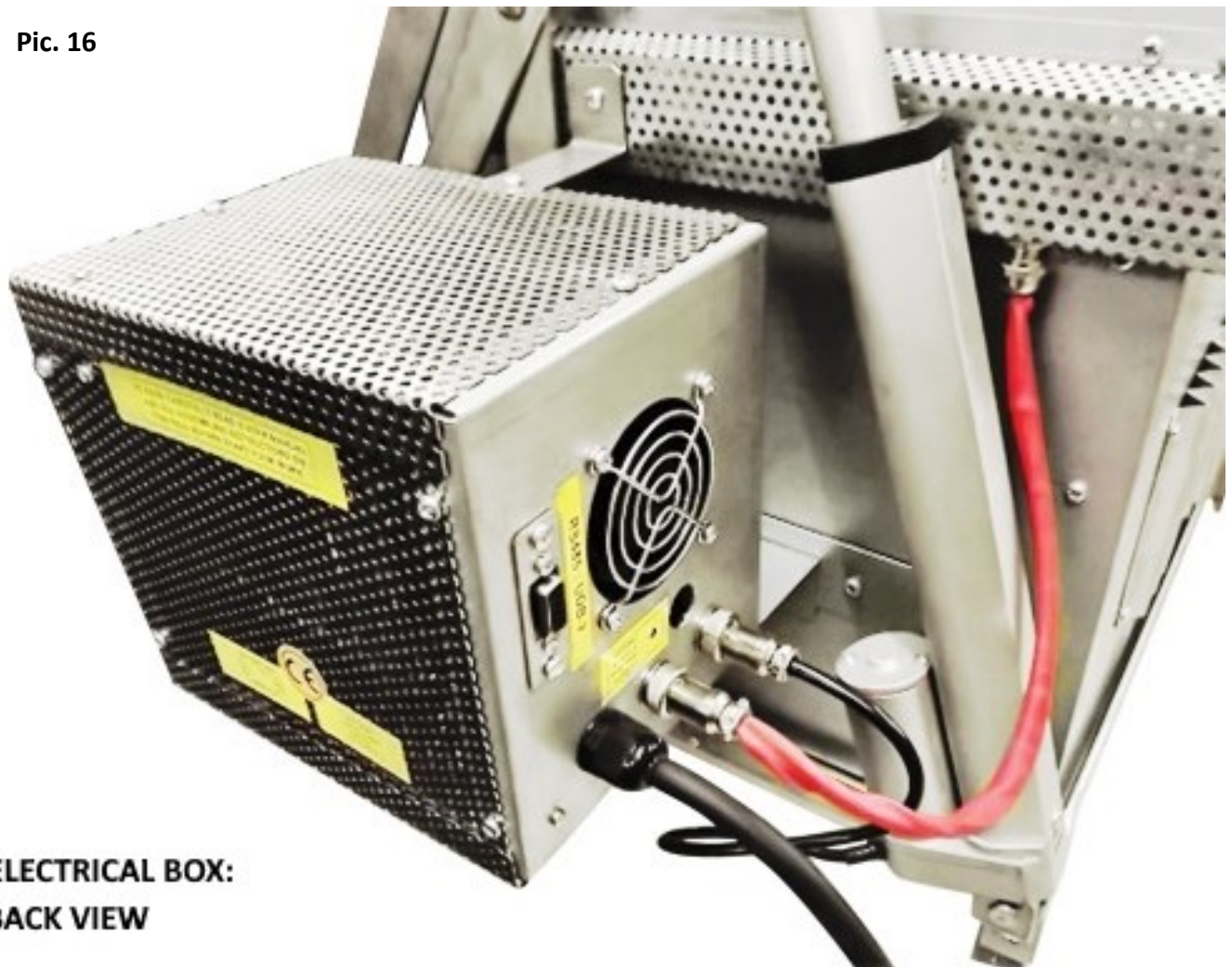
Pic. 16**ELECTRICAL BOX:
BACK VIEW**

⇒ Your kiln is now fully assembled and ready to operate. Before you connect it to a power supply, you should fully understand how the remote control (handset) works. Take the remote control and compare it with the sample picture below:

⇒ Please ensure that you have clearly understood all of the remote's functions. It can be used for turning your kiln ON and OFF or opening and closing your kiln's door from up to 20 metres away. Please remember that you do not need to press any buttons continuously; all of them are activated with a simple CLICK:

- Click the "Lock" button to turn your kiln ON or to STOP the door moving in any position.

- Click the "square" button to turn your kiln OFF.

- Click the "^" button to open the door.

- Click the "Y" button to close the door.

⇒ Please do not try to stop the door moving by pressing on the "square" button. This will disconnect the kiln from the power supply and you will have to restart your program from the beginning. To stop the door in any position press the "^" or "Y" button.

⇒ If you need to stop the heating process immediately then please use the RED emergency button. To release it later simply turn the button clockwise until you hear a "click".

⇒ Your kiln also has two ventilation holes on the door with shutters, as shown in the picture below.

◆ When using the kiln for the first time, it must be heated up for approximately 90 minutes (factory setting) to allow any water to evaporate from the chamber. Please do not be alarmed if light smoke and/or a smell appears (when using the kiln for the FIRST time). This is normal for new kilns as any water, grease or oils burn out from the heating element(s), shelves, chamber and from inside the kiln. It should not happen again after the first time it is heated. If your kiln is used less than once a month then please repeat this process each time you use it.

◆ Please also note that the temperature shown on the controller is the temperature around the thermocouple(s) inside the kiln's chamber. You may have to wait up to two hours for the inside of your kiln to heat up fully and reach the same temperature everywhere inside the chamber.

◆ See the next page to learn how to program the temperature controller.

SAMPLE OF REMOUTE CONTROL (FOR MODEL R310-PBC):

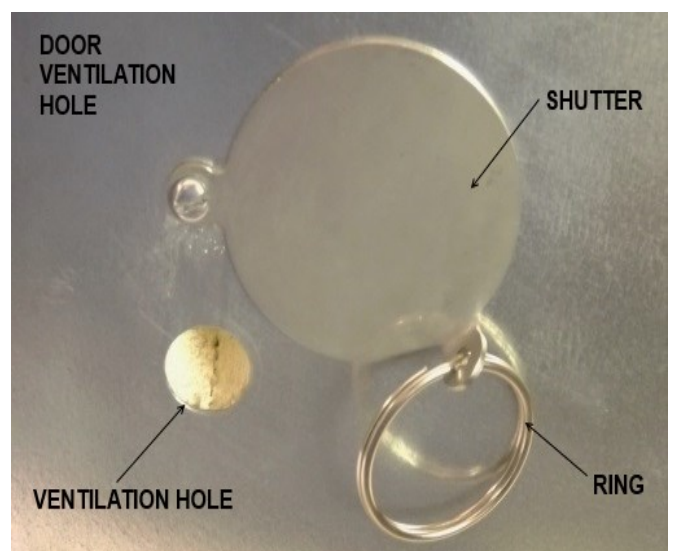
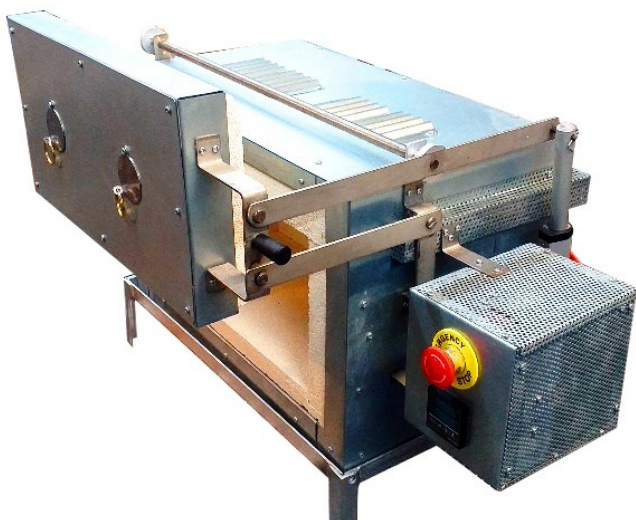
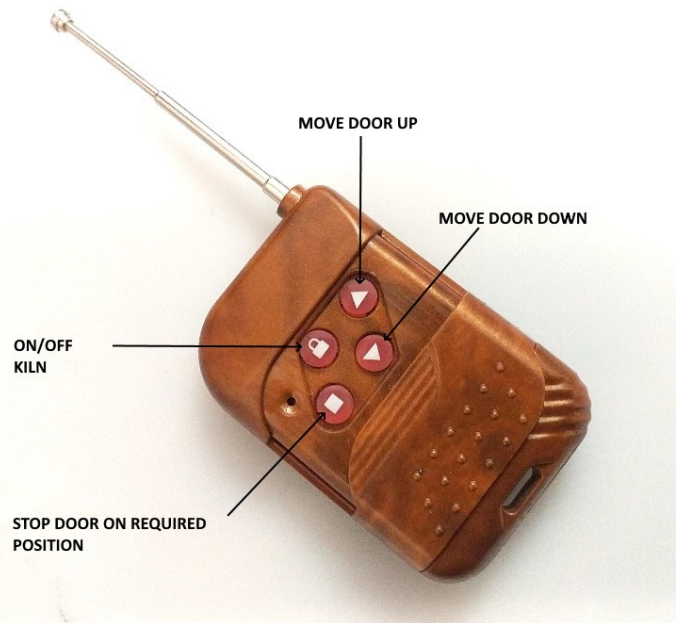

TEMPERATURE CONTROLLER:

The programmable temperature controller (XMTG-7000) has already been set up for chamber drying by the manufacturer (if you have not requested a different setting). If you want to re-program this controller, please refer to the controller's user manual or contact us for help on Skype. Below are some useful tips for using this controller:



1. "SET" – setting/confirmation button (used for setting all of the controller's parameters).

2. "Arrow Left" or "A/M" – segment selector (to choose from four segments).

3. "Arrow Down" – decrease (used to set the required temperature).

4. "Arrow Up" – increase (used to set the required temperature).

Example program: Increase from room temperature up to 450°C within 99 minutes, soak at 450°C for 4 minutes and then decrease to room temperature within 145 minutes.

Example instructions:

1. Open your kiln's door to trigger the safety-switch mechanism, which will disconnect the power supply from the heating element(s) and prevent the kiln from heating up while you program the temperature controller. Alternatively, simply press button 4 for 3 seconds until you see "STOP" on the bottom display. Now you can start programming your controller.
2. Each of the following steps consists of first setting the temperature and then setting the time period in which the NEXT temperature should be reached. There are 32 available input slots each consisting of a pair of temperature and time inputs, i.e. there are a total of 32 temperature inputs alternating with 32 time inputs. To start programming, short-press the 'SET' button.
3. After you have pressed the 'SET' button, you will set the starting temperature ("C1" on the top display). In this case, input the desired room temperature (usually 20°C), i.e. "0020", into the BOTTOM display using buttons 2, 3 and 4. Now press 'SET' to confirm this initial temperature and to proceed to the next input ("Γ1"). This input is the required TIME to reach the NEXT required temperature. For this example, insert "0099" (99 minutes) into the BOTTOM display, and then press 'SET' again to set this input and to proceed to the next step.
4. The next step begins by setting the second required temperature ("C2"). To set this, insert "0450" (450°C) into the bottom display. Next, press 'SET' again to proceed to the next input ("Γ2"), where you will set the required time to the NEXT temperature. In this case, this is our soaking time of 4 minutes - "0004". Press 'SET' again to confirm this time and to proceed to the next step.
5. The next step begins by setting the third required temperature ("C3"), in this case the required soaking temperature. Enter "0450" (450°C) into the bottom display again. Next press 'SET' once more to proceed to the next time input ("Γ3"), which in this case will be 145 minutes. Input "0145" into the bottom display, then press 'SET' again.
6. For the next step, set the fourth and final required temperature ("C4") – "0020" (20°C).
7. To indicate the end of the program, press the 'SET' button again, insert "0000" into the bottom display and press the 'SET' button once more. Your program will automatically finish when it reaches this last input.

A. When you have finished programming the controller, short-press the 'SET' button or simply leave the controller for about 30 seconds for your new setting to be remembered and for your job to start.

B. Close the kiln door to disconnect the safety-switch mechanism, allowing your kiln to start heating up. Alternatively, if you pressed button 4 in step 1 above, now press button 3 for 3 seconds until the word "RUN" appears on the bottom display.

C. Important: you'll have about 20-30 seconds to change EACH temperature/time setting. Please do not worry if you take too much time and the controller resets and starts displaying the current temperature inside the chamber again. Simply restart the programming process by short-pressing the 'SET' button again. If you are a beginner and are having difficulty programming your controller, please feel free to contact the manufacturer or agent/shop for free help with this matter during the warranty period.

D. You can find detailed information about the controller's settings and all of its functions in the controller's user manual. We do not recommend changing the manufacturer's setting yourself (except for any programs) as this can cause the factory settings to be lost and may result in you needing to fully reset and/or re-calibrate the controller in future, which is NOT COVERED BY THE WARRANTY.

SAFETY INSTRUCTIONS and USEFUL TIPS FOR BEGINNERS:

- ⇒ Please make sure that any item(s) you place inside the chamber are not touching the heating element(s) at the top.
- ⇒ It is always best to conduct some tests on a small quantity of your firing material before you fire your item(s).
- ⇒ Using this kiln continuously for longer than 30 minutes at temperatures of 1,200°C may cause problems with the heating element(s) and/or with the kiln's metal body that are NOT covered by the warranty.
- ⇒ This kiln must be placed on a level surface that will not be damaged by heat. A masonry or concrete floor is recommended, but other protective materials like metal or ceramic (tiles) sheets may be used.
- ⇒ Please note that the kiln door can only be fixed in position when using the linear actuator! Manually opening the door is only allowed in emergencies. If you open the door manually please hold it securely the whole time you need to access the chamber.
- ⇒ Always make sure that the door is closed correctly as this speeds up the heating process and saves electricity.
- ⇒ If you can't turn your kiln ON check if the emergency switch is released by fully turning the RED plastic button clockwise.
- ⇒ Only manually open/close the door with gloves.
- ⇒ Always use heat-resistant gloves and long metal tweezers to remove or place item(s) from/into the kiln.
- ⇒ This kiln should be kept away from all inflammable materials and other heating devices.
- ⇒ When the door is open at temperatures higher than 200°C (392°F), always maintain as much distance as possible between you and the hot chamber. Please also wear dark glasses to avoid any problems with your eyes.
- ⇒ Because of the high temperatures that this kiln can reach, you should never leave it unattended when it is in use.
- ⇒ Never touch the kiln's metal body and shutter on the door without gloves on as these can burn your hands.
- ⇒ KEEP OUT OF REACH OF CHILDREN.
- ⇒ Disconnect the kiln from its power supply when not in use.
- ⇒ For a small additional charge this kiln can be also supplied with a laser-based internal automatically air extraction system.

WARNING: This is an electrical, often extremely hot piece of equipment: always follow any applicable health and safety rules and regulations for electrical equipment and hot work in your country.